

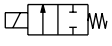









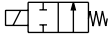
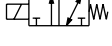
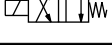
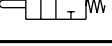
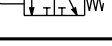
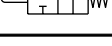
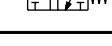
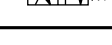
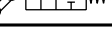
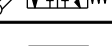
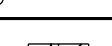
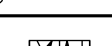

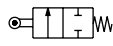

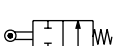
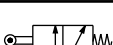
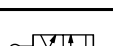
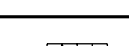
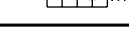
Informações Técnicas

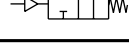
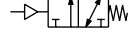
Pressão de trabalho: 2 a 10 bar.
Materiais: corpo de alumínio, êmbolo de latão, molas de aço zincado e vedações em Buna-N.
Orifício: 7 mm.
Vazão: 600 l/min.

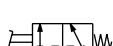
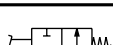
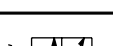
* A tensão da bobina pode ser pedida conforme a sua própria nomenclatura. Ex.: WS-3-1/4"-220
** Quando desejar válvula normal aberta, acrescentar após o código, NA. Ex.: WS-3-1/4"-220NA

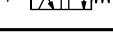
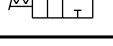
Referência	Simbologia	Atuador/Retorno	Nº de Vias
WS-2-1/4"		Solenóide/Mola	2
WS-3-1/4"		Solenóide/Mola	3
WS-2-1/4" NA		Solenóide/Mola	2
WS-3-1/4" NA		Solenóide/Mola	3
WS-4-1/4"		Solenóide/Mola	4
WE-2-1/4"		Esfera/Mola	2
WE-3-1/4"		Esfera/Mola	3
WE-2-1/4" NA		Esfera/Mola	2
WE-3-1/4" NA		Esfera/Mola	3
WE-4-1/4"		Esfera/Mola	4
WG-2-1/4"		Gatilho/Mola	2
WG-3-1/4"		Gatilho/Mola	3
WG-2-1/4" NA		Gatilho/Mola	2
WG-3-1/4" NA		Gatilho/Mola	3
WG-4-1/4"		Gatilho/Mola	4

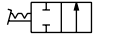
WR-2-1/4"		Rolete/Mola	2
WR-3-1/4"		Rolete/Mola	3
WR-2-1/4" NA		Rolete/Mola	2
WR-3-1/4" NA		Rolete/Mola	3
WR-4-1/4"		Rolete/Mola	4
WI-2-1/4"		Piloto/Mola	2
WI-3-1/4"		Piloto/Mola	3
WI-2-1/4" NA		Piloto/Mola	2
WI-3-1/4" NA		Piloto/Mola	3
WI-4-1/4"		Piloto/Mola	4
WP-2-1/4"		Pedal/Mola	2
WP-3-1/4"		Pedal/Mola	3
WP-2-1/4" NA		Pedal/Mola	2
WP-3-1/4" NA		Pedal/Mola	3
WP-4-1/4"		Pedal/Mola	4
WP-2-T		Pedal/Trava	2
WP-3-T		Pedal/Trava	3
WP-2-T NA		Pedal/Trava	2
WP-3-T NA		Pedal/Trava	3
WP-4-T		Pedal/Trava	4



Solenóide/Mola - 2/2 e 3/2

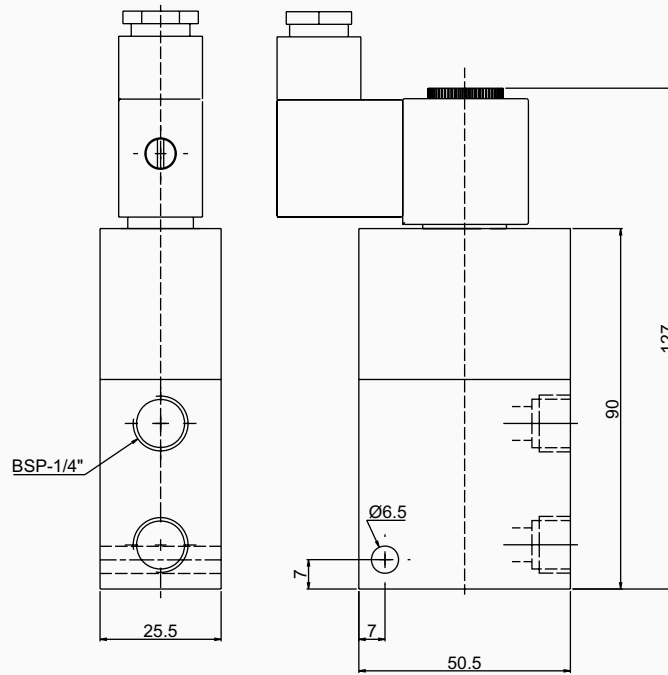

Solenóide/Mola - 4/2 - referência: WS-4-1/4\"/>

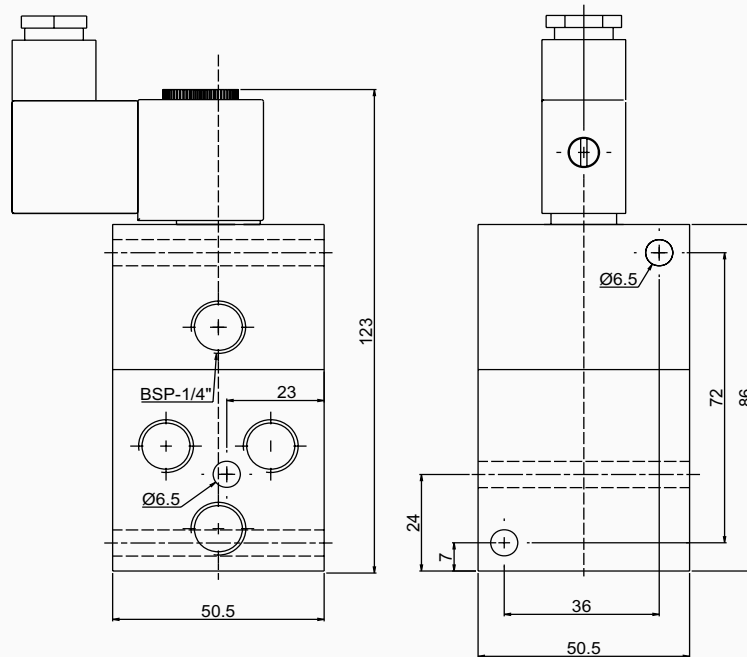

Esfera/Mola - 2/2 e 3/2

Esfera/Mola - 4/2

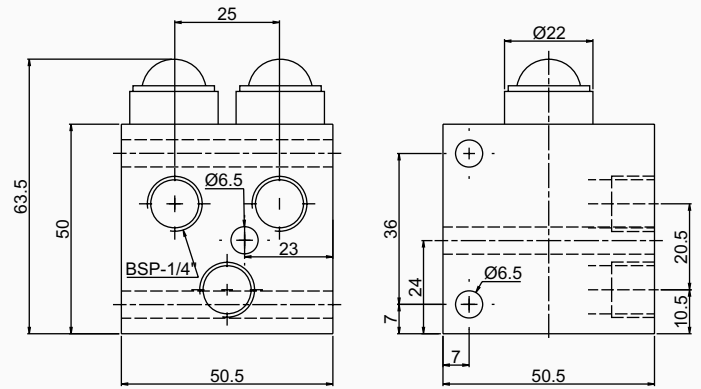
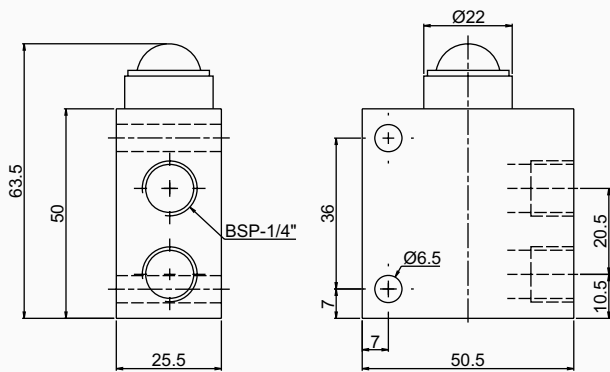

Gatilho/Mola - 2/2 e 3/2

Gatilho/Mola - 4/2

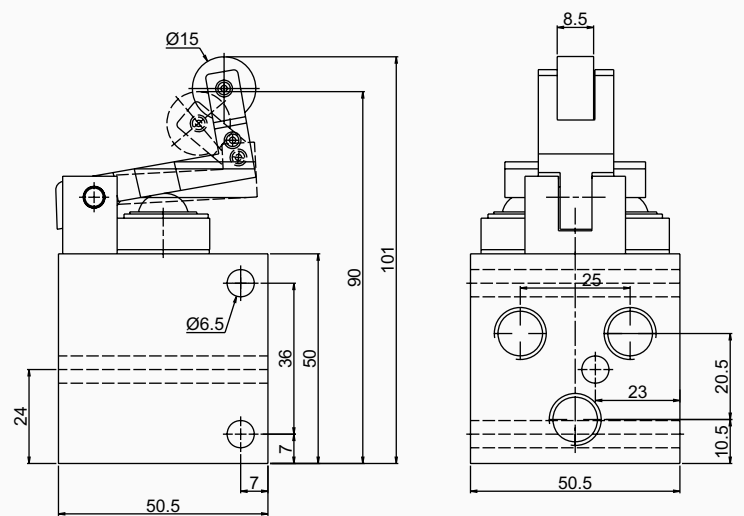
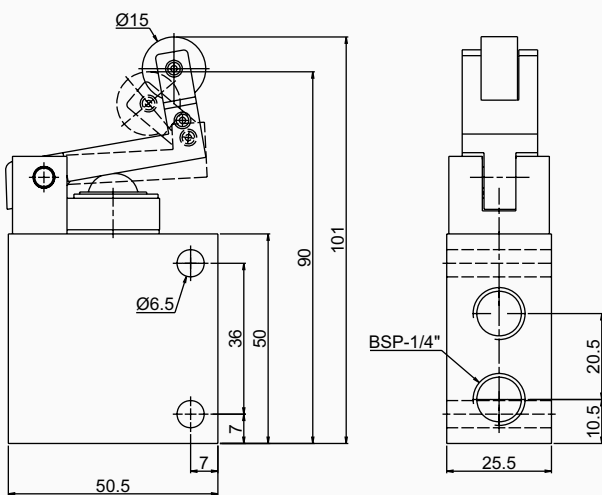

Rolete/Mola - 2/2 e 3/2

Rolete/Mola - 4/2

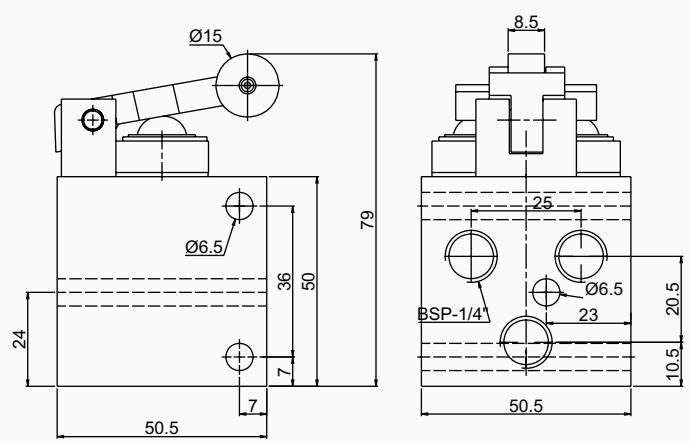
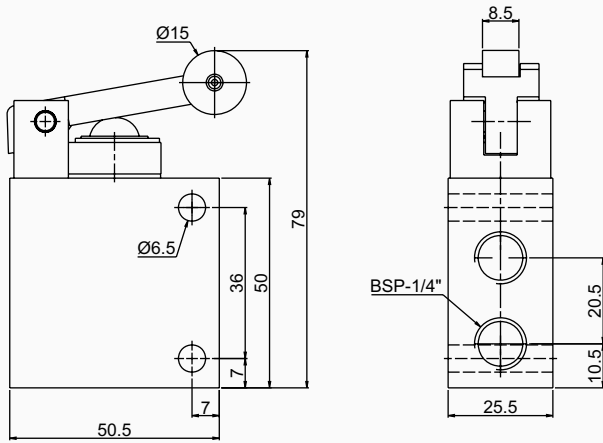

Piloto/Mola - 2/2 e 3/2

Piloto/Mola - 4/2

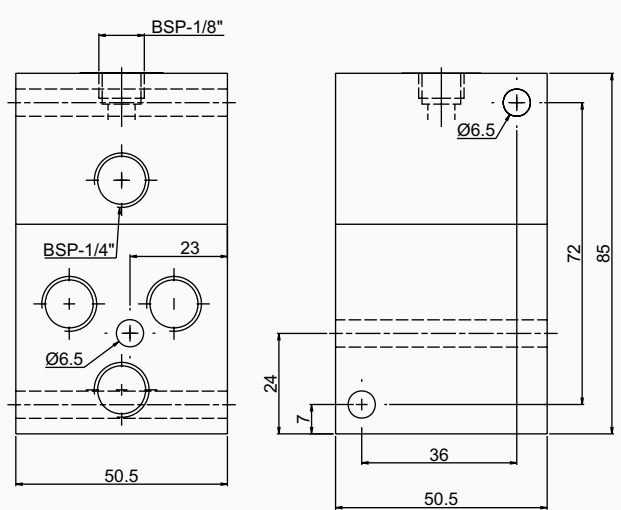
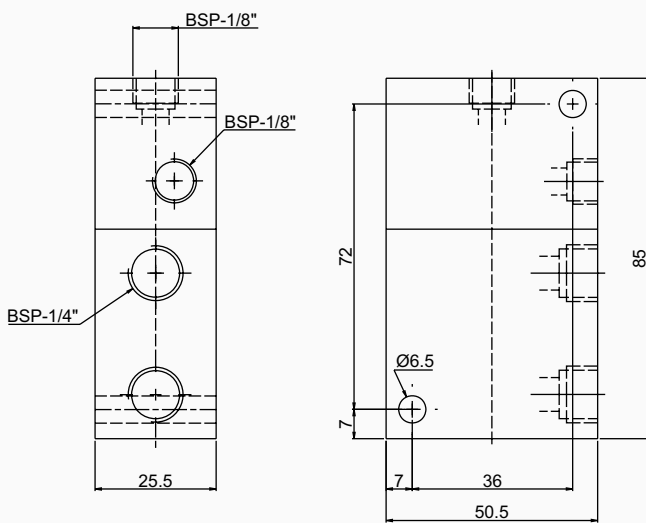

Pedal/Mola - 2/2, 3/2 e 4/2 Pedal/Trava - 2/2, 3/2 e 4/2

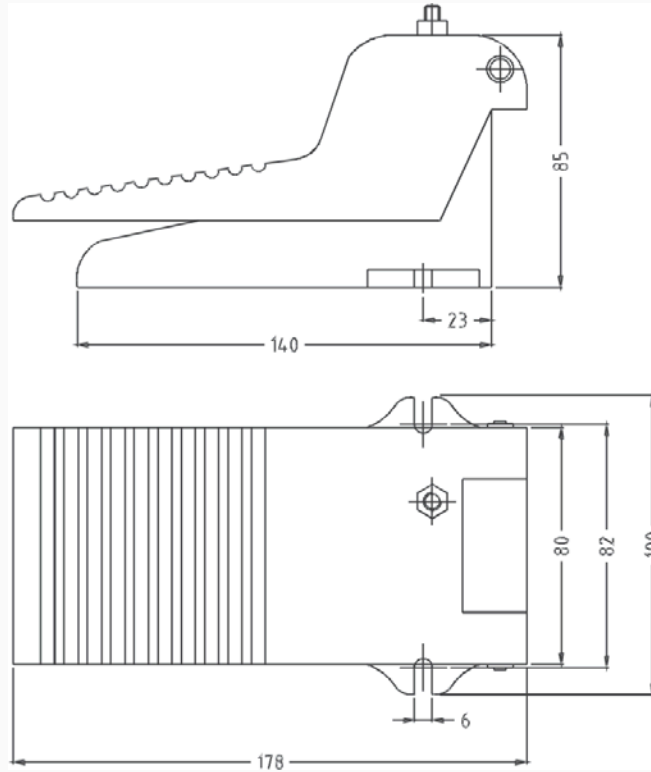

Kitde Reparos

ATUADOR	
E	ESFERA
G	GATILHO
I	PILOTO
P	PEDAL
R	ROLETE
S	SOLENÓIDE*

Nº DE VIAS	
2	2 VIAS
3	3 VIAS
4	4 VIAS
5	2 VIAS NA
6	3 VIAS NA

W - - **000**